

# A FLANSCHAUSFÜHRUNG

Zentrierung nach DIN 332 Blatt 2

Paßfeder nach DIN 6885 Blatt 1

LECKÖL DRUCKLOS ABFÜHREN

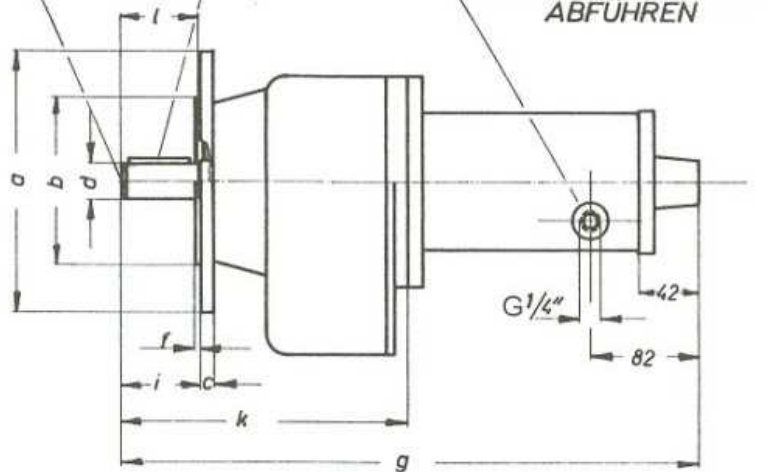
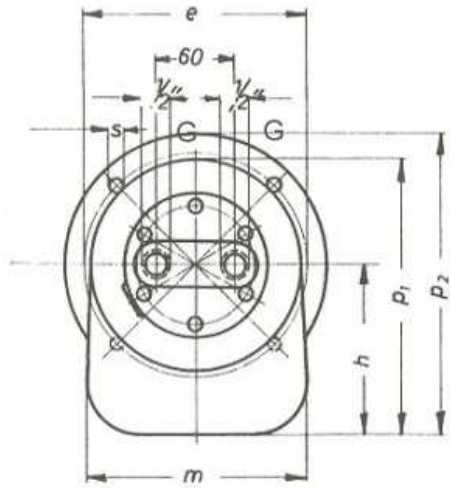

33	HM4 - HM7	250	180 <sub>js</sub>	16	40 <sub>ks</sub>	215	4	470	173	80	250	80	200	273	298	14
30	HM4 - HM7	200	130 <sub>js</sub>	12	35 <sub>ks</sub>	165	35	439	153	70	219	70	170	238	253	11
25	HM4 - HM7	200	130 <sub>js</sub>	12	30 <sub>ks</sub>	165	35	441	128	70	221	70	170	213	228	11
Getriebe	Motoren	a	b	c	d	e	f	g	h	i	k	l	m	p <sup>1</sup>	p <sup>2</sup>	s

Gewicht ca.

Typ 33+ Motor=34,2 kg

Typ 30+ Motor=26,2 kg

Typ 25+ Motor=24,2 kg

# B FUSSAUSFÜHRUNG

Untersetzungen und Drehmomente siehe Blatt SK 3.2

Bestellbeispiel: HM5 - 107/30

Hydromotor

Getriebe

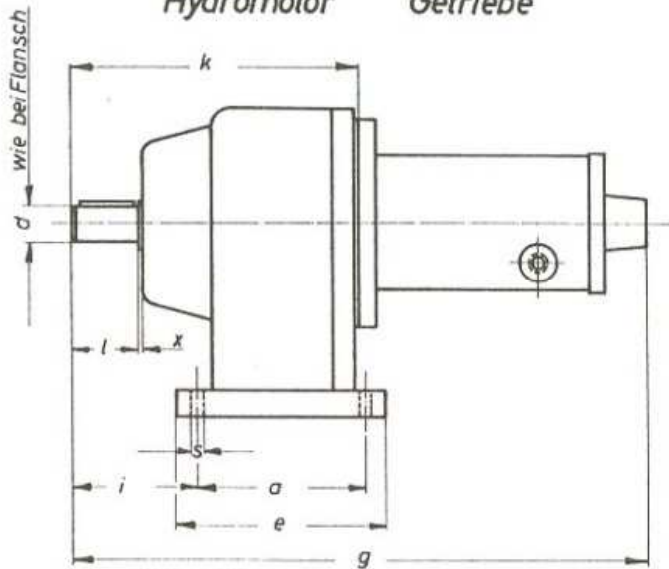
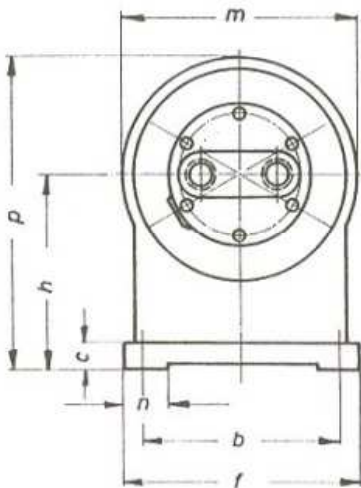

33	HM4 - HM7	134	175	25	165	215	470	175	120	250	80	200	40	275	13	3
30	HM4 - HM7	90	185	20	125	210	439	155	86	219	70	170	35	240	13	3
25	HM4 - HM7	140	155	20	175	190	441	130	115	221	70	170	35	215	13	2
Getriebe	Motoren	a	b	c	e	f	g	h	i	k	l	m	n	p	s	x

HYDRO - GETRIEBEMOTOREN Blatt 2

SK 101.3.2



MW Hydraulik GmbH

Tel: 06188 81291  
Fax: 06188 8454

Lange Hecke 3  
63796 Kahl